

V-9975 SEVEN BAND EQUALIZER

INTRODUCTION

These instructions contain the specifications and information necessary to install, operate, and maintain the V-9975, Seven Band Equalizer.

SPECIFICATIONS

Features

- 7 active filters
- Modified 1 octave equalization
- ± 12 dB boost or cut
- Constant Q equalization
- Power "ON" indicator
- Bypass switch to remove EQ from circuit (slide type)
- High impedance output
- Line output

Nominal Specifications

- Type of Inputs:
 - Hi impedance 10K Ohms (unbalanced)
 - Stereo HiZ 10K Ohms (unbalanced)
- Type of Outputs:
 - Line (balanced)
 - Hi impedance 10K Ohms (unbalanced)
- Frequency Response: 35Hz-20kHz ± 1 dB
- Distortion: $< 0.3\%$
- Frequency Centers:
 - Band 1 = 60 Hz
 - 2 = 200 Hz
 - 3 = 560 Hz
 - 4 = 1100 Hz
 - 5 = 2200 Hz
 - 6 = 4500 Hz
 - 7 = 10000Hz

Power Requirements

- -24VDC
- 150 mA

Dimensions/Weight

- 5.7" H x 8.1" W x 2.5" D
(14.5cm W x 20.6cm H x 6.4cm D)
- 2.8 lbs. (1.27 kg)



Environment

- Temperature: 0 to 50 Degrees C
- Humidity: 0-85% non-precipitating

OPERATION

The V-9975 is used to boost or attenuate specific frequencies to improve voice intelligibility or attenuate frequencies to help reduce feedback. The unit can also be used to modify the frequency response of speakers.

A "POWER" indicating LED, 7 slide controls (1 for each of the bands), and an "EQ" bypass switch are located on the front of the unit. The frequencies boost/cut (1 to 12 dB), are modified with each filter's slide control. The manual "EQ" bypass switch allows comparison of before equalization, and after effect, in the area being equalized. All frequency adjustments are bypassed when the "EQ IN/OUT" switch is in the "OUT" position.

INSTALLATION

Connections are accomplished utilizing (3) phono jacks (2 input, 1 output) and/or (9) screw terminals. Only qualified service personnel should install the V-9975. See Figures 1 and 2 for actual connections. After all connections are made and slide controls adjusted to the desired positions, close security cover and tighten locking screws. All connections should be made and double checked before DC power is supplied to the unit.

Mounting

The V-9975 is designed for wall mounting. To mount the unit, install (2) #8 sheet metal screws provided into the wall 6-1/4 inch apart. Screw heads should protrude from wall no more than 1/16 inch. Hang unit on screws. With security cover open, install (1) #8 sheet metal screw in slot located at bottom of unit and tighten, to complete the mounting.

TECHNICAL ASSISTANCE

When trouble is reported, verify that DC power is being supplied to the unit and there are no shorts or grounds on cabling. Assistance in troubleshooting is available from the factory. When calling, you should have a VOM and a telephone test set available and be calling from the job site. Call (540) 427-3900 and ask for Technical Support, or call (540) 427-6000 for

Valcom 24-hour Automated Support or visit our website at <http://www.valcom.com>.

Valcom equipment is not field repairable. Valcom, Inc. maintains service facilities in Roanoke, VA. Should repairs be necessary, attach a tag to the unit clearly stating company name, address, phone number, contact person, and the nature of the problem. Send the unit to:

**Repair and Return Dept.
Valcom, Inc.
5614 Hollins Road
Roanoke, VA 24019-5056**

VALCOM LIMITED WARRANTY

Valcom, Inc. warrants its products to be free from defects in materials and workmanship under conditions of normal use and service for a period of one year from the date of shipment. The obligation under this warranty shall be limited to the replacement, repair or refund of any such defective device within the warranty period, provided that:

1. inspection by Valcom, Inc. indicates the validity of the claim,
2. the defect is not the result of damage, misuse, or negligence after the original shipment.
3. the product has not been altered in any way or repaired by others and that factory sealed units are unopened (A service charge plus parts and labor will be applied to units defaced or physically damaged),
4. freight charges for the return of products to Valcom are prepaid,
5. all units 'out of warranty' are subject to a service charge. The service charge will cover minor repairs (Major repairs will be subject to additional charges for parts and labor).

This warranty is in lieu of and excludes all other warranties, expressed or implied, and in no event shall Valcom, Inc. be liable for any anticipated profits, consequential damages, loss of time or other losses incurred by the buyer in connection with the purchase, operation, or use of the product.

This warranty specifically excludes damage incurred in shipment. In the event a product is received in damaged condition, the carrier should be notified immediately. Claims for such damage should be filed with the carrier involved in accordance with the F.O.B. point.

Headquarters:
Valcom, Inc.
1111 Industry Avenue
Roanoke, VA 24013
Phone: (540) 427-3900
FAX: (540) 427-3517

In Canada
CMX Corporation
35 Van Kirk Drive #11 and 12
Brampton, Ontario L7A1A5
Phone: (905) 456-1072
FAX: (905) 456-2269

FIGURE 1 - CONNECTIONS

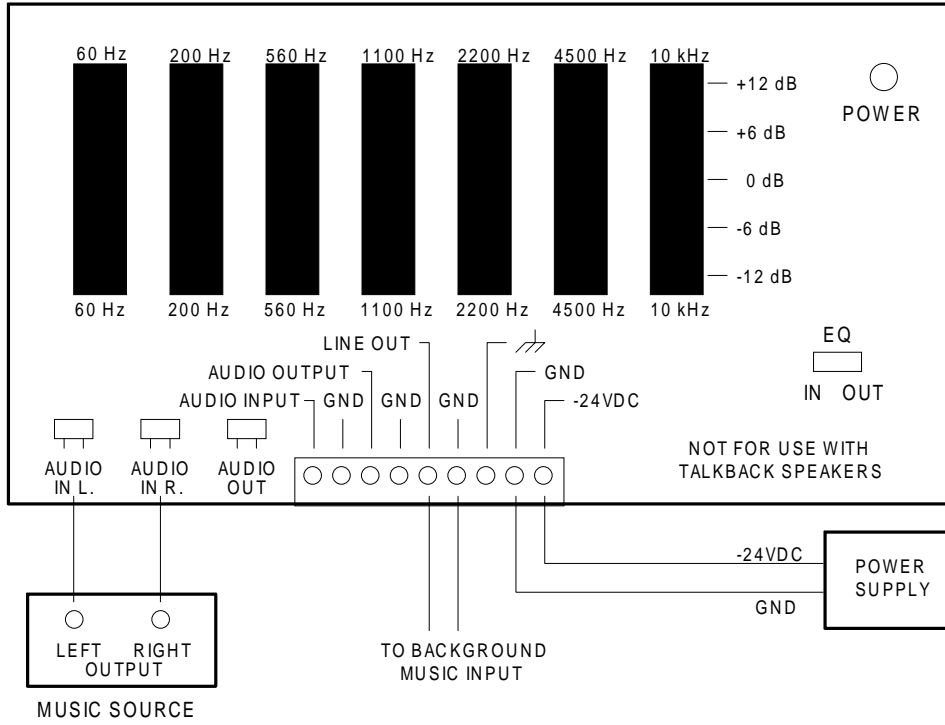

FIGURE 2 - CONNECTIONS

