

VALCOM LIMITED WARRANTY

Valcom, Inc. warrants its products to be free from defects in materials and workmanship under conditions of normal use and service for a period of one year from the date of shipment. The obligation under this warranty shall be limited to the replacement, repair or refund of any such defective device within the warranty period, provided that:

1. inspection by Valcom, Inc. indicates the validity of the claim,
2. the defect is not the result of damage, misuse, or negligence after the original shipment.
3. the product has not been altered in any way or repaired by others and that factory sealed units are unopened (A service charge plus parts and labor will be applied to units defaced or physically damaged),
4. freight charges for the return of products to Valcom are prepaid,
5. all units 'out of warranty' are subject to a service charge. The service charge will cover minor repairs (Major repairs will be subject to additional charges for parts and labor).

This warranty is in lieu of and excludes all other warranties, expressed or implied, and in no event shall Valcom, Inc. be liable for any anticipated profits, consequential damages, loss of time or other losses incurred by the buyer in connection with the purchase, operation, or use of the product.

This warranty specifically excludes damage incurred in shipment. In the event a product is received in damaged condition, the carrier should be notified immediately. Claims for such damage should be filed with the carrier involved in accordance with the F.O.B. point.

Headquarters:
Valcom, Inc.
1111 Industry Avenue
Roanoke, VA 24013
Phone: (540) 427-3900
FAX: (540) 427-3517

In Canada:
CMX Corporation
35 Van Kirk Drive #11 and 12
Brampton, Ontario L7A1A5
Phone: (905) 456-1072
FAX: (905) 456-2269

INSTALLATION INSTRUCTIONS FOR

VALCOM

SURFACE MOUNT DOOR SPEAKER V-1074



TROUBLESHOOTING CHART

PROBLEM	CORRECTIVE ACTION
No sound in page mode.	<ul style="list-style-type: none"> • Check tip and ring for audio at speaker. • Check tip and ring at control unit.
Low volume in page mode.	<ul style="list-style-type: none"> • Check volume controls at page control. • Check for open circuits in wiring.
Poor listening in talkback mode.	<ul style="list-style-type: none"> • Check talkback volume controls at page control. • Set control at minimum suitable listening level.

V-1074 DOOR SPEAKER

The V-1074 Talkback Door Speaker can be used with all Valcom Handsfree Talkback Page Controls, Door Answering Units, or any control with a 45 ohm speaker output. It can be surface mounted with the two screws provided or mounted in a single-gang electrical box.

Dimensions/Weight

- 5.5"H x 4.0"W x 1.125"D (13.97cm H x 10.16cm W x 2.86cm D)
- 0.5 lbs. (.23 kg)

INSTALLATION

NOTES:

Connect using unshielded, twisted pair cable and limit runs to 800 feet or less. Up to three (3) pair cable may be required when connecting to the door speaker.

After making wire connections, cover uninsulated connections with silicone tape, insulating putty or paint, to prevent tracking.

1. Connect TIP and RING from the Valcom Page Control speaker output to the speaker connections (marked TIP and RING) on the Door Speaker as shown below.
2. Connect CALL button on the Door Speaker to the customer provided signal equipment as shown below. Switch is rated at 100 mA maximum current.

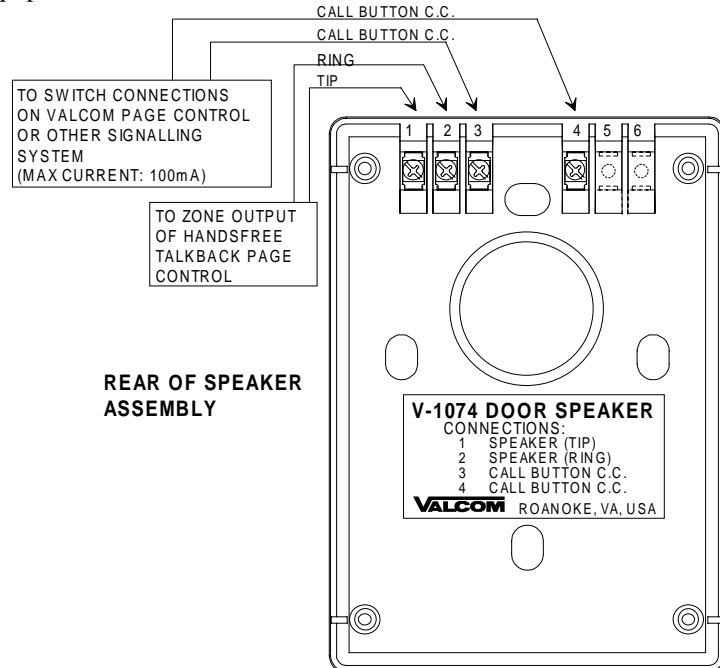

MOUNTING

The V-1074 has mounting holes located on the rear of the unit. To mount, open the enclosure by inserting a flat blade screwdriver in the slot at the bottom of the unit and prying the front assembly away from the mounting plate. Position the mounting plate at the desired location and fasten to the wall or electrical box using the screws provided. When connections are complete, snap the front assembly to the mounting plate.

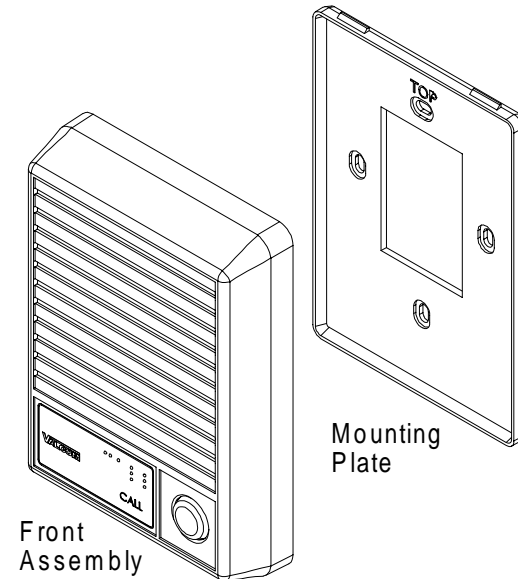

TECHNICAL ASSISTANCE

When trouble is reported, verify there are no broken connections to the unit. Assistance in troubleshooting is available from the factory. When calling, you should have a Volt-ohm meter and a lineman's test set available and be calling from the job site. Call (540) 427-3900 and ask for Technical Support, or (540) 427-6000 for Valcom 24-hour Automated Support or visit our website at <http://www.valcom.com>.

Valcom equipment is not field repairable. Valcom, Inc. maintains service facilities in Roanoke, VA. Should repairs be necessary, attach a tag to the unit clearly stating your company name, address, phone number, contact person, and the nature of the problem. Send the unit to:

Valcom, Inc.
Repair and Return Dept.
5614 Hollins Road
Roanoke, VA 24019-5056